

Melguizo-Ibáñez, E.; Zurita-Ortega, F.; Ubago-Jiménez, J.L.; González-Valero, G.; Ortega-Caballero, M. (202x) Sports Motivation, Anxiety and Diet in Education Students. Revista Internacional de Medicina y Ciencias de la Actividad Física y el Deporte vol. X (X) pp. xx. [Http://cdeporte.rediris.es/revista/___*](http://cdeporte.rediris.es/revista/)

ORIGINAL

SPORTS MOTIVATION, ANXIETY AND DIET IN EDUCATION STUDENTS

MOTIVACIÓN DEPORTIVA, ANSIEDAD Y DIETA EN ESTUDIANTES DE EDUCACIÓN

Melguizo-Ibáñez, E.¹; Zurita-Ortega, F.¹; Ubago-Jiménez, J.L.¹; González-Valero, G.²; Ortega-Caballero, M.³

¹ Department of Didactics of Musical, Plastic and Corporal Expression, University of Granada. Faculty of Educational Sciences (Spain) edumeliba@correo.ugr.es felixzo@ugr.es jubago@ugr.es

² Department of Didactics of Musical, Plastic and Corporal Expression, University of Granada. Faculty of Education and Sports Sciences of Melilla. Melilla Campus (Spain) ggvaler@ugr.es

³ Department of Pedagogy. University of Granada. Faculty of Education and Sports Sciences of Melilla. Melilla Campus (Spain) manorca@ugr.es

Spanish-English translator: Emily Knox, Emily_knox2@hotmail.co.uk

Código UNESCO: 6114.03 Psicología Social. Comportamiento Colectivo/ Social Psychology. Collective Behaviour.

Clasificación del Consejo de Europa: 15. Psicología del deporte/ Sport Psychology

Recibido 10 de agosto de 2021 **Received** August 10, 2021

Aceptado 15 de abril de 2022 **Accepted** April 15, 2022

ABSTRACT

Motivational development with regards to sport plays a fundamental role in sport performance, however, anxiety and dietary patterns also play a key role. In consideration of the above, the present research aimed to develop an explanatory model of the motivational climate towards sport and its relationship with the Mediterranean diet and anxiety. This structural model was then examined according to gender using multi-group analysis. To this end, a cross-sectional, descriptive and comparative study was carried out with 556 university students. The instruments used were a sociodemographic questionnaire, the Perceived Motivational Climate in Sport Questionnaire (PMCSQ-2), the Beck Anxiety Inventory (BAI) and the Predimed questionnaire. Finally, outcomes revealed that the female gender had a negative relationship with adherence to a healthy dietary pattern, whilst males showed better adherence to the Mediterranean diet and higher levels of anxiety.

KEYWORDS: Sport motivation; Anxiety; Mediterranean Diet; Gender; Undergraduates

RESUMEN

La motivación juega un papel fundamental en la práctica del ejercicio físico, sin embargo, la ansiedad y el patrón dietético también juegan un rol clave, por tanto, la presente investigación refleja los objetivos de desarrollar un modelo explicativo del clima motivacional hacia el deporte y su relación con la dieta mediterránea y la ansiedad y contrastar el modelo estructural mediante un análisis multigrupo en función del sexo. Se ha realizado un estudio descriptivo comparativo de corte transversal con 556 estudiantes universitarios. Los instrumentos utilizados han sido un cuestionario sociodemográfico, el Cuestionario de Clima Motivacional Percibido en el Deporte (PMCSQ-2), el Inventario de Ansiedad de Beck (BAI) y el cuestionario Predimed. Finalmente, los resultados revelan que el sexo femenino tiene una relación negativa con la adherencia positiva a un patrón dietético saludable, mientras que el masculino muestra una mejor adherencia hacia la dieta mediterránea y mayores niveles de ansiedad.

PALABRAS CLAVE: Motivación deportiva; Ansiedad; Dieta Mediterránea; Sexo; Estudiantes universitarios.

INTRODUCTION

Motivation is currently one of the most studied issues in sport psychology. Due to its great potential for explaining different human behaviours, it can be defined as a mechanism through which the intensity and direction of effort is controlled (Claver et al., 2020; Conde-Pipó et al., 2021; González-Valero et al., 2022; Sánchez et al., 2020). In addition, achievement goal theory (Nicholls, 1989) also includes the term motivational climate. This is defined as the perception held by individuals of the different indicators present in their environment and forms the basis on which success or failure of the performance of a given activity is defined (Wang et al., 2018). The establishment of a certain motivational climate will, therefore, depend on the motivations guiding individuals towards engaging in specific activities. More specifically, in the physical and sporting field, when physical activity engagement is oriented towards expertise, values such as enjoyment or personal satisfaction (task climate) are important, whereas when extrinsic values are emphasised, competition is encouraged (ego climate) (Mabuta and Leapetswe, 2016; Zurita-Ortega et al., 2016). This generates an increase in levels of frustration and anxiety when proposed objectives are not achieved (Li et al., 2019).

Another highly studied factor in the field of psychology is anxiety. This is considered to be a negative psycho-emotional disorder characterised by a manifestation of feelings of worry and nervousness (Gao et al., 2020). However, research carried out by Kayani et al. (2021) and Linares-Manrique et al. (2016) affirms that physical activity oriented by intrinsic motivations helps to reduce levels of anxiety. Furthermore, Castro-Sánchez et al. (2019) and Trigueros et al.

(2020) concluded that when sport begins to be performed professionally, anxiety increases as participants focus on competitiveness and neglect enjoyment and fun.

Likewise, anxiety can also play a negative role in individuals' diets. A study conducted by Han et al. (2021) argued that individuals living with high levels of anxiety followed increasingly worse dietary patterns. Furthermore, such individuals engage in emotional consumption, in which excessive quantities of food are consumed in order to improve the way in which one feels about themselves. The dietary pattern referred to as the Mediterranean diet is characterised as a healthy and beneficial diet for health as it has a reduced intake of fats and a high intake of monounsaturated fatty acids (Muros et al. 2017). Moreover, it has also been shown to improve individual physical health (Cortés-Morales et al., 2022). The predominant foods in this dietary pattern are whole grains, olive oil, bread and dairy products, vegetables, fruits and nuts, amongst others (Ubago-Jiménez et al., 2020). High adherence to this eating pattern brings health benefits such as reduced waist circumference, increased lifespan and reduced risk of developing severe symptoms following COVID-19 infection (Chesnut et al., 2021). Finally, a study carried out by Ferrer-Cascales et al. (2019) found that following this dietary pattern provided benefits regarding the control of emotions, as well as the channelling of disruptive states, such as anxiety, depression and stress.

Finally, the aims of the present research were to identify and establish the relationship between sport motivation, anxiety and adherence to the Mediterranean diet. This involved (a) developing an explanatory model of sport motivation, anxiety and adherence to the Mediterranean diet as a function of self-reported gender and (b) examining the structural model as a function of the self-reported gender of participants.

MATERIAL AND METHODS

Sample and design

A descriptive, non-experimental (ex post facto) and cross-sectional design was used for the present research. The sample was selected via convenience and consisted of 556 university students belonging to degrees related to education. Of the overall sample, 75% were female (n=417) and 25% were male (n=139). In terms of age, participants were between 18 and 30 years old (M=25.09; SD=6.22). Sampling error was set at 5%, with the final sample size enabling a 97% confidence level.

Instruments and variables

The following instruments were used:

- **Socio-demographic questionnaire** used to collect variables such as gender (male or female) and age.

- **Perceived Motivational Climate in Sport Questionnaire (PMCSQ-2)**, developed by Newton et al. (2000). The Spanish version adapted by González-Cutre et al. (2008) was used in the present research. This questionnaire consists of 33 items rated on a five-point Likert scale (1 = strongly disagree and 5 = strongly agree). It assesses motivation according to two dimensions: task climate (consisting of three sub-dimensions: effort, improvement and cooperative learning) and ego climate (consisting of three sub-levels: unequal recognition, punishment of mistakes and rivalry between members). Internal reliability of the task climate scale was 0.925, while that of the ego climate scale was 0.912.
- **Beck Anxiety Inventory**, developed by Beck et al. (1988). For the present study, the Spanish version developed by Sanz and Navarro (2003) was used. This questionnaire is composed of a total of 21 items, which are rated on a four-point Likert scale (0= not at all and 3= very much). In the present research a Cronbach alpha of 0.936 was obtained.
- **Predimed questionnaire**, developed by Schöder et al. (2011). In the present study, the version developed by Álvarez-Alvarez et al. (2019) was used. This instrument is composed of 14 items. Final scores for each item are summed together to obtain an overall score. From this, participant responses are classified according to three levels: low adherence (≤ 7), medium adherence (8-10), and high adherence (≤ 10). In the present research, a Cronbach alpha 0.815 was obtained.

Procedure

In the first step, a search of current literature was carried out in order to identify issues addressed in existing research. Following this, a Google form was developed by the Department of the Didactics of Musical, Artistic and Corporal Expression at the University of Granada. This form included all of the instruments described above. Participants were explained the study aims and informed consent was obtained. Questionnaires were sent out using various media, however, due to the public health situation at the time of writing, digital means were used for the most part. In addition, two questions were intentionally repeated within the questionnaire in order to test for random responding. A total of 25 questionnaires were discarded due to incorrect completion. The principles set out in the 1975 Declaration of Helsinki were followed at all times, guaranteeing the anonymity and rights of participants. Finally, the ethics committee of the University of Granada approved the present research (1230/CEIH/2020).

Data analysis

The IBM SPSS Statics 25.0 statistical programme (IBM Corp, Armonk, NY, USA) was used for descriptive analysis of data. In this sense, an analysis of frequencies and means was carried out. In addition, Cronbach's alpha was used to determine the internal consistency of instruments, setting the reliability index at 95%. In order to examine the distribution of data, the Kolmogorov-Smirnov test was used and confirmed a normal distribution.

The IBM SPSS Amos 26.0 program (IBM Corp., Armonk, NY, USA) was used to establish the relationships between the variables that composed the theoretical model through the construction of structural equation models (Figure 1). In this sense, a general model was developed for the overall study sample, alongside two different models which were used to examine relationships between variables according to participant sex. With regards to the latter, the proposed models were composed of eight endogenous and two exogenous variables. In the case of the endogenous variables, causal explanations were made in consideration of the observed associations between the indicators, in addition to measurement reliability. In this way, measurement error pertaining to the observed variables could be included and controlled for in the model, enabling more accurate interpretation of multivariate regression coefficients. In addition, diagrams were developed in which one-way arrows represent lines of influence between latent variables and are interpreted from regression weights. Furthermore, a significance level of 0.05 was established using Pearson's chi-square test.

The variables anxiety and adherence to the Mediterranean diet act as endogenous variables which are influenced by the motivational climate (task and ego), with anxiety also being influenced by Mediterranean diet adherence.

Finally, model fit was assessed after estimating the different model parameters. Following the recommendations of McDonald and Marsh (1990) and Bentler (1990), goodness of fit was assessed using Chi-square, with non-significant p-values indicating good model fit. The comparative fit index (CFI; values above 0.95 indicate good model fit), goodness-of-fit index (GFI; values above 0.90 indicate acceptable fit), incremental reliability index (IFI; values above 0.90 indicate acceptable fit) and root mean square approximation (RMSEA; values below 0.1 indicate acceptable model fit) were also used.

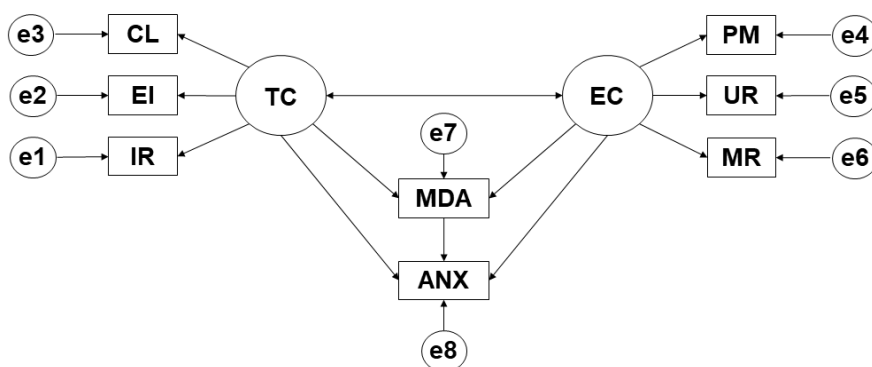

Figure 1: Proposed theoretical model. **Note:** Task Climate (TC); Cooperative Learning (CL); Effort/Improvement (EI); Important Role (IR); Ego Climate (EC); Punishment for Mistakes (PM); Unequal Recognition (UR); Member Rivalry (MR); Adherence to Mediterranean Diet (MDA); Anxiety (ANX)

RESULTS

The proposed model developed from data collected from a sample of university students aged 18-30 years showed good fit for all indices. Chi-square analysis produced a significant p-value ($X^2= 76.799$; $df=16$; $p=0.000$), although this

outcome cannot be interpreted in isolation given the sensitivity of this indicator to sample size (Tenenbaum and Eklund, 2007). Thus, other standardised fit indices were also used. The comparative fit index (CFI) obtained was 0.968, which represents an excellent score. The normalised fit (NFI), incremental fit (IFI) and Tucker-Lewis (TLI) indices obtained were 0.961, 0.969 and 0.929, respectively all of which point to excellent fit. In addition, root mean square error of approximation analysis (RMSEA) analysis also obtained an acceptable value of 0.039.

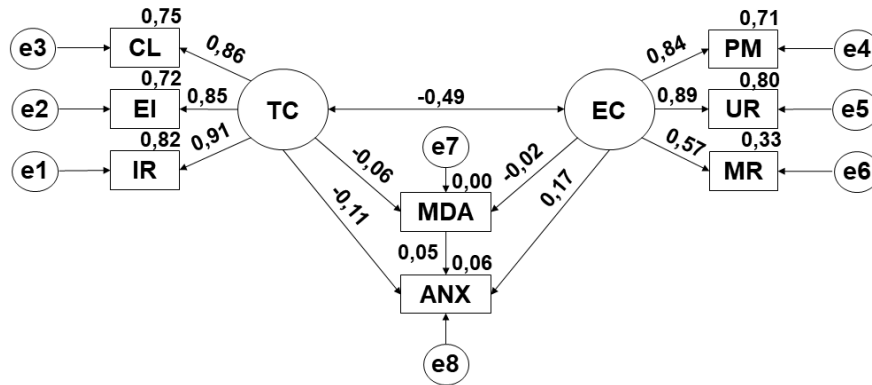

Figure 2: Structural equation of the theoretical model. **Note:** Task Climate (TC); Cooperative Learning (CL); Effort/Improvement (EI); Important Role (IR); Ego Climate (EC); Punishment for Mistakes (PM); Unequal Recognition (UR); Member Rivalry (MR); Adherence to Mediterranean Diet (MDA); Anxiety (ANX).

Table 1: Outcomes pertaining to the theoretical model

Associations between variables	RW				SRW
	Estimation	EE	CR	p	Estimation
MDA←TC	-0.009	0.008	-1.125	0.260	-0.060
MDA←EC	-0.004	0.010	-0.387	0.699	-0.021
IR←TC	1.000				0.907
EM←EC	0.793	0.030	26.360	***	0.846
AC←EC	0.984	0.036	27.181	***	0.864
PM←EC	1.000				0.840
UR←EC	1.362	0.071	19.232	***	0.892
MR←EC	0.776	0.057	13.592	***	0.572
ANX←TC	-0.094	0.043	-2.199	0.028	-0.113
ANX←EC	0.163	0.050	3.263	***	0.172
ANX←MDA	0.263	0.222	1.187	***	0.049
EC ←→TC	-0.253	0.028	-8.985	***	-0.494

Note 1: Regression Weights (RW); Standardised Regression Weights (SRW); Estimation Error (EE); Critical Ratio (CR). **Note 2:** Task climate (TC); Cooperative Learning (CL); Effort/Improvement (EM); Important Role (IR); Ego Climate (EC); Punishment of Mistakes (PM); Unequal Recognition (UR); Member Rivalry (MR); Mediterranean Diet Adherence (MDA); Anxiety (ANX). **Note 3:** *** $p < 0.001$

Both figure 2 and table 1 present the regression weights obtained in the theoretical model, with statistically significant relationships being established at $p < 0.001$. In this case, anxiety was negatively associated with task climate (TC) ($r = -0.113$), whilst it was positively related with ego climate (EC) ($p < 0.001$; $r = 0.172$) and Mediterranean diet adherence (MDA) ($p < 0.001$; $r = 0.049$). With

regards to task climate (TC), a positive relationship was found with effort/improvement (EI) ($p < 0.001$; $r = 0.846$) and cooperative learning (CL) ($p < 0.001$; $r = 0.864$), although a negative relationship was shown with Mediterranean diet adherence (MDA) ($r = -0.060$) and ego climate (EC) ($p < 0.001$; $r = -0.494$). Finally, with respect to ego climate, it was identified to have a negative relationship with Mediterranean diet adherence (MDA) ($r = -0.021$) and a positive relationship with punishment of mistakes (PM) ($r = 0.840$), unequal recognition (UR) ($r = 0.892$) and rivalry between members (MR) ($r = 0.572$).

Turing attention to the model developed pertaining to males, good scores were produced for all indices. Chi-square analysis produced a significant p-value ($\chi^2 = 26.752$; $df = 16$; $pl = 0.000$). Comparative fit (CFI), normalised fit (NFI) and incremental fit (IF) indices were 0.977, 0.946 and 0.978, respectively. In addition, the Tucker-Lewis index (TLI) was 0.960, whilst the root mean square error of approximation (RMSEA) value was 0.053.

Figure 3 and table 2 present the regression weights produced in this theoretical model, with statistically significant relationships at the level of $p < 0.001$ being highlighted. Anxiety (ANX) was positively related with ego climate (EC) ($p < 0.001$; $r = 0.333$) and Mediterranean diet adherence (MDA) ($r = 0.026$), whilst also being negatively related with task climate (TC) ($r = -0.247$). As for task climate (TC), this was negatively related with Mediterranean diet adherence (MDA) ($r = -0.052$) and ego climate (EC) ($p < 0.001$; $r = -0.443$), whilst also being positively related with important role (IR) ($r = 0.894$), effort/improvement (EI) ($p < 0.001$; $r = 0.874$) and cooperative learning (CL) ($p < 0.001$; $r = 0.865$). Finally, ego climate (EC) showed positive relationships with adherence to the Mediterranean diet (MDA) ($r = 0.050$), punishment of mistakes ($r = 0.900$), unequal recognition (UR) ($p < 0.001$; $r = 0.806$) and rivalry between members (MR) ($p < 0.001$; $r = 0.506$).

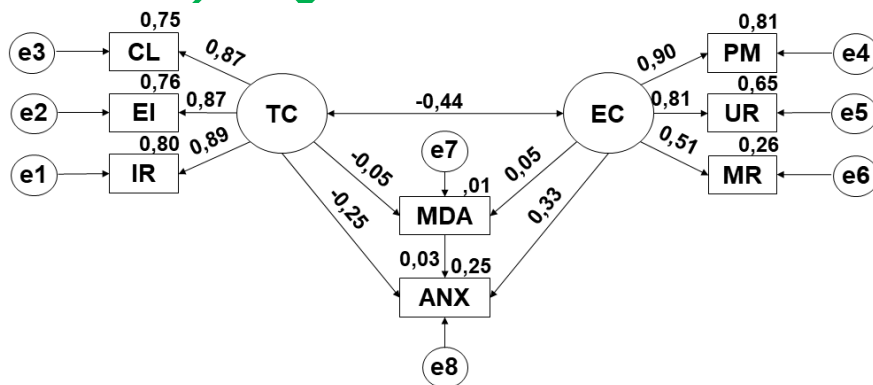

Figure 3: Proposed structural equation model for males. **Note:** Task Climate (TC); Cooperative Learning (CL); Effort/Improvement (EI); Important Role (IR); Ego Climate (EC); Punishment for mistakes (PM); Unequal Recognition (UR); Member Rivalry (MR); Adherence to Mediterranean Diet (MDA); Anxiety (ANX).

Table 2: Structural equation model pertaining to males

Associations between variables	RW				SRW.
	Estimation	EE	CR	P	Estimation
MDA←TC	-0.009	0.017	-0.502	0.616	-0.052
MDA←EC	0.009	0.019	0.472	0.637	0.050
IR←TC	1.000				0.894
EI←TC	0.887	0.065	13.630	***	0.874
CL←TC	0.968	0.072	13.431	***	0.865
PM←EC	1.000				0.900
UR← EC	1.115	0.129	8.632	***	0.806
MR←EC	0.683	0.119	5.714	***	0.506
ANX←MDA	0.155	0.458	0.338	0.735	0.026
ANX←TC	-0.248	0.092	-2.693	0.007	-0.247
ANX←EC	0.371	0.107	3.455	***	0.333
EC←→TC	-0.190	0.046	-4.162	***	-0.443

Note 1: Regression Weights (RW); Standardised Regression Weights (SRW); Estimation Error (EE); Critical Ratio (CR). **Note 2:** Task climate (TC); Cooperative Learning (CL); Effort/Improvement (EM); Important Role (IR); Ego Climate (EC); Punishment of Mistakes (PM); Unequal Recognition (UR); Member Rivalry (MR); Mediterranean Diet Adherence (MDA); Anxiety (ANX). **Note 3:** *** $p < 0.001$

Finally, in the case of females, Chi-square analysis produced a significant p-value ($X^2 = 67.127$; $df = 16$; $pl = 0.000$). Further, comparative fit (CFI), normalised fit (NFI) and incremental fit (IFI) indices were 0.965, 0.955 and 0.970, respectively. As for the Tucker-Lewis index (TLI), a value of 0.948 was obtained, whilst the root mean square error of approximation (RMSEA) was 0.048.

Figure 4 and table 3 present the regression weights produced by the theoretical model, with statistically significant relationships at the level of $p < 0.001$ being indicated. Turning attention to anxiety (ANX), a negative relationship was found with task climate (TC) ($r = -0.066$), however, a positive relationship was observed with ego climate (EC) ($r = 0.152$) and Mediterranean diet adherence (MDA) ($r = 0.051$). As for this latter variable (MDA), a negative relationship was uncovered with task climate ($r = -0.068$) and ego climate ($r = -0.051$). With regards to ego climate (EC), a positive relationship was found with punishment of mistakes (PM) ($p < 0.001$; $r = 0.824$), unequal recognition (UR) ($p < 0.001$; $r = 0.913$) and rivalry between group members (MR) ($p < 0.001$; $r = 0.578$), whilst a negative relationship was found with task climate (TC) ($p < 0.001$; $r = -0.511$). Finally, with regards to task climate (TC), a positive relationship was observed with

important role (IR) ($p < 0.001$; $r = 0.908$), effort/improvement (EI) ($p < 0.001$; $r = 0.839$) and cooperative learning (CL) ($p < 0.001$; $r = 0.863$).

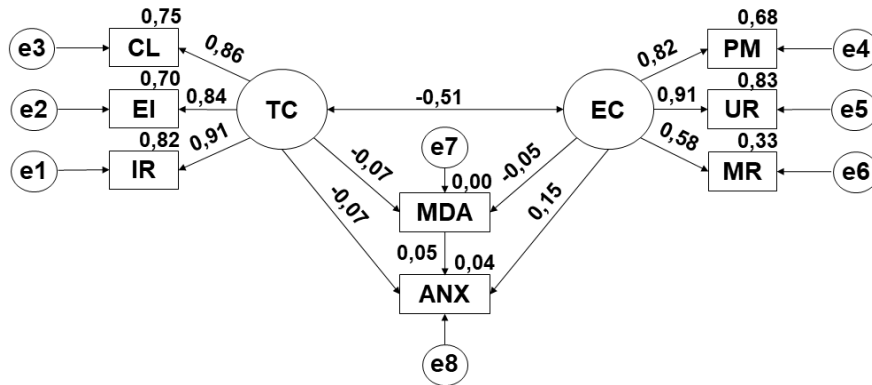

Figure 3: Proposed structural equation model for females. **Note:** Task Climate (TC); Cooperative Learning (CL); Effort/Improvement (EI); Important Role (IR); Ego Climate (EC); Punishment for mistakes (PM); Unequal Recognition (UR); Member Rivalry (MR); Adherence to Mediterranean Diet (MDA); Anxiety (ANX).

Table 3: Structural equation model pertaining to females

Associations between variables	RW				SRW
	Estimation	EE	CR	p	Estimation
MDA ← TC	-0.010	0.069	-1.097	0.272	-0.068
MDA ← EC	-0.009	0.011	-0.810	0.418	-0.051
IR ← TC	1.000				0.908
EI ← TC	0.772	0.034	22.448	***	0.839
CL ← TC	0.994	0.042	23.402	***	0.863
PM ← EC	1.000				0.824
UR ← EC	1.427	0.084	16.923	***	0.913
MR ← EC	0.786	0.065	11.997	***	0.578
ANX ← MDA	0.262	0.247	1.061	0.289	0.051
ANX ← TC	-0.051	0.048	-1.077	0.282	-0.066
ANX ← EC	0.136	0.055	2.451	0.014	0.152
EC ↔ TC	-0.273	0.034	-7.932	***	-0.511

Note 1: Regression Weights (RW); Standardised Regression Weights (SRW); Estimation Error (EE); Critical Ratio (CR). **Note 2:** Task climate (TC); Cooperative Learning (CL); Effort/Improvement (EI); Important Role (IR); Ego Climate (EC); Punishment of Mistakes (PM); Unequal Recognition (UR); Member Rivalry (MR); Mediterranean Diet Adherence (MDA); Anxiety (ANX). **Note 3:** *** $p < 0.001$

DISCUSSION

The present research outlines the relationship between motivations developed towards the physical activity engagement and the impact of such motivation on the control of anxiety and adherence to healthy dietary patterns. In this way, obtained outcomes meets the proposed objectives. The present discussion, therefore, strives to compare findings of the present study with those produced in other previous research.

When considering the general model, it can be observed that, regardless of the motivations held towards engagement in physical exercise, negative relationships towards a healthy dietary pattern emerge. Very different outcomes

were obtained by Chacón-Cuberos et al. (2019), with Slack et al. (2020) and Teichert et al. (2020) arguing that the launch of fast-food apps on smartphones plays a negative role in relation to eating behaviours, as the speed of acquiring food is prioritised over its quality and health benefits. Likewise, it was also observed that adherence to a healthy dietary pattern did not help to reduce anxiety levels. This finding contrasts with that reported by Marchena et al. (2020) and may be explained by Ubago-Jiménez et al. (2020) who argues that, during the university stage, there is a lack of dietary control due to students opting for an excessive intake of proteins and fats. In addition, it was also found that anxiety levels were lower when engagement in physical exercise was oriented towards a task climate. However, when physical activity engagement was oriented towards an ego climate, a positive relationship emerged with anxiety. Similar findings were reported by Gómez López et al. (2021), with Dimas et al. (2021) also arguing that when engagement in physical exercise is guided by extrinsic motivations, higher levels of anxiety are developed in order to achieve the proposed goals.

Moving on to consider the models developed as a function of sex, it is observed that, in the female population, physical activity or sport engagement is negatively related with healthy dietary patterns, regardless of the motivation guiding engagement. In contrast, in the male population, a positive relationship emerges when sport engagement is oriented towards a task climate. Hugely contrasting findings were reported by Santos-Labrador (2018) who found that females were more likely to adhere to Mediterranean diet. This being said, research conducted by Stanton et al. (2020) found that, due to the crisis caused by the COVID-19 pandemic and its impact on negative emotions, an increase in the practice of emotional overeating (Trigueros et al. 2020) has led to the worsening of dietary patterns. Furthermore, a negative relationship between anxiety and task climate was observed regardless of sex, although this relationship was stronger within males. Similar findings were reported by Fernández et al. (2020) and may be explained using arguments raised by Tahtinen and Kristjansdóttir (2019) that females are more likely to employ other techniques to cope with disruptive states, whilst males tend to opt for physical exercise as a way to feel good about themselves and channel negative emotions.

In consideration of all of the above, it should be noted that the present study identified a relationship between motivation towards sport and the impact of this on adherence to healthy eating patterns and the channelling of anxiety. Thus, Physical Education classes should encourage attitudes in which intrinsic motivations play a fundamental role and personal satisfaction is valued more highly than competition (Castro-Sánchez et al., 2019; González-Valero et al., 2017; Melguizo-Ibáñez et al., 2022; Sanz-Martín, 2015).

The present research also has a number of limitations. A cross-sectional design was employed meaning that it is not possible to establish cause-effect relationships between variables or establish changes over time. In addition, the sample recruited came from a very specific geographical area. This means that it is not possible to generalise findings to a wider geographical context.

With a view to future perspectives in light of the present findings, future research should strive to develop interventions targeted towards future Physical Education teachers in Andalusia, which seek to have an impact on the control of anxiety, development of motivation towards physical activity engagement and dietary patterns.

CONCLUSIONS

Overall, acceptable values were obtained for the different parameters of the general model. The present study shows that the development of intrinsic motivation towards physical activity engagement has a positive impact on the channelling of disruptive states, in this case, anxiety. However, with respect to adherence to a healthy dietary pattern, negative relationships were observed regardless of motivational orientation, with a positive relationship with anxiety also emerging.

In consideration of the models developed according to sex, it was observed that, in the female population, physical activity engagement was negatively related with adherence to a healthy dietary pattern, regardless of the motivation developed, whereas, in the male population, a negative relationship only emerged when sport engagement was oriented towards an ego climate. Furthermore, when it comes to coping with anxiety, males reported higher scores in relation to a task climate than females, who reported similar scores regardless of the climate examined. The relationship between anxiety and diet adherence was similar in both sexes.

Finally, it can be stated that sex plays a key role in the development of motivation towards sport. Such motivation may influence the channelling of anxiety and adherence to healthy dietary patterns. This being said, motivation does not appear to play a key role on the relationship between Mediterranean diet adherence and coping with anxiety.

REFERENCES

- Álvarez-Álvarez, I., Martínez-González, M.A., Sánchez-Tainta, A., Corella, D., Díaz-López, A., Fitó, M., Vioque, J., Romaguera, D., Martínez, J.A., Warnberg, J., López-Miranda, J., Estruch, R., Bueno-Cavanillas, A., Arós, F., Tur, J.A., Tnahones, F.J., Serrá-Majem, L., Martín, V., Lapetra, J. ... y Toledo, E. (2019). Dieta Mediterránea hipocalórica y factores de riesgo cardiovascular: análisis transversal de PREDIMED-Plus. *Revista Española de Cardiología*, 72(11), 925-934.
<https://doi.org/10.1016/j.recesp.2018.08.007>
- Beck, A.T., Epstein, N., Brown, G. y Steer, R.A. (1988). AN Inventory for measuring clinical anxiety: Psychometric properties. *Journal of Consulting and Clinical Psychology*, 56, 893-897.
<https://doi.org/10.1037/0022-006X.56.6.893>
- Bentler, P. M. (1990). Comparative fit indexes in structural models. *Psychological Bulletin*, 107, 238-246.
- Castro-Sánchez, M., Zurita-Ortega, F., Chacón-Cuberos, R. y Lozano-Sánchez, A.M. (2019). Motivational climate and levels of anxiety in soccer players

of lower divisions. *Retos: Nuevas tendencias en educación física, deporte y recreación*, (35), 164-169.

<https://doi.org/10.47197/retos.v0i35.63308>

Castro-Sánchez, M., Zurita-Ortega, F., Zafrá-Santos, E., Rodríguez-Fernández, S., Chacón-Cuberos, R., & Valdivia-Moral, P. (2019). Motivación en la práctica del judo en deportistas no profesionales. *Revista Internacional De Medicina Y Ciencias De La Actividad Física Y Del Deporte*, 19(74), 1-16. <https://doi.org/10.15366/rimcafd2019.74.005>

Chacón-Cuberos, R., Badicu, G., Zurita-Ortega, F. y Castro-Sánchez, M. (2019). Mediterranean diet and motivation in sport: A comparative study between university students from Spain and Romania. *Nutrients*, 11(1), 1-14. <https://doi.org/10.3390/nu11010030>

Chesnut, W.M., MacDonald, S. y Wambier, C.G. (2021). Could diet and exercise reduce risk of COVID-19 syndemic? *Medical Hypotheses*, 148, 1-3. <https://doi.org/10.1016/j.mehy.2021.110502>

Claver, F., Martínez-Aranda, L.M., Conejero, M. y Gil-Arias, A. (2020). Motivation, Discipline, and Academic Performance in Physical Education: A Holistic Approach From Achievement Goal and Self-Determination Theories. *Frontiers in Psychology*, 11, 1-11. <https://doi.org/10.3389/fpsyg.2020.01808>

Conde-Pipó, J., Melguizo-Ibáñez, E., Mariscal-Arcas, M., Zurita-Ortega, F., Ubago Jiménez, J.L., Ramírez-Granizo, I. y González-Valero, G. (2021). Physical Self-Concept Changes in Adults and Older Adults: Influence of Emotional Intelligence, Intrinsic Motivation and Sports Habits. *International Journal of Environmental Research and Public Health*, 18(4), 1-15. <https://doi.org/10.3390/ijerph18041711>

Cortes-Morales, P. J., Dias de Jesus, E. E., Sierpinski, T. C., & Faltarone Brasilino, F. (2022). Analysis of Physical Fitness and Anthropometry of Students in School Physical Education. *ESHPA - Education, Sport, Health and Physical Activity*, 6(1), 50-60. <http://doi.org/10.5281/zenodo.5517365>

Dimas, M.A., Galway, S.C. y Gammage, K.L. (2021). Do you see what I see? The influence of self-objectification on appearance anxiety, intrinsic motivation, interoceptive awareness, and physical performance. *Body Image*, 39, 53-61. <https://doi.org/10.1016/j.bodyim.2021.05.010>

Fernández, M.M., Brito, C.J., Miarka, B. y Díaz-de-Durana, A.L. (2020). Anxiety and Emotional Intelligence: Comparisons Between Combat Sports, Gender and Levels Using the Trait Meta-Mood Scale and the Inventory of Situations and Anxiety Response. *Frontiers in Psychology*, 11, 1-14. <https://doi.org/10.3389/fpsyg.2020.00889>

Ferrer-Cascales, R., Albaladejo-Blázquez, N., Ruiz-Robledillo, N., Clement-Carbonell, V., Sánchez-SanSegundo, M. y Zaragoza-Martí, A. (2019). Higher Adherence to the Mediterranean Diet is Related to More Subjective Happiness in Adolescents: The Role of Health-Related Quality of Life. *Nutrients*, 11(3), 1-12. <https://doi.org/10.3390/nu11030698>

Gao, W.J., Ping, S.Q. y Liu, X.Q. (2020). Gender differences in depression, anxiety, and stress among college students: A longitudinal study from China. *Journal of Affective Disorders*, 263, 292-300. <https://doi.org/10.1016/j.jad.2019.11.121>

- Gómez-López, Courel-Ibáñez, J. y Granero-Gallegos, A. (2021). Profiles of motivation, fear of failure and anxiety in young handball players: A cross-sectional study. *International Journal of Sports Science and Coaching*, 16(3), 658-669. <https://doi.org/10.1177/1747954120975107>
- González-Cutre, D., Sicilia, A. y Moreno, J. (2008). Modelo cognitivo-social de la motivación de logro en educación física. *Psicothema*, 20(4), 642-651.
- González-Valero, G., Bastida-Castillo, A., Gómez-Carmona, C., Corral-Pernía, J., Melguizo-Ibáñez, E., & Puertas-Molero, P. (2022). Condición psicosocial de los profesores de Educación Física según las características sociodemográficas (Psychosocial status of Physical Education teachers according to socio-demographic characteristics). *Retos*, 44, 1090-1098. <https://doi.org/10.47197/retos.v44i0.91907>
- González-Valero, G., Zurita-Ortega, F., & Martínez-Martínez, A. (2017). Panorama motivacional y de actividad física en estudiantes: una revisión sistemática. *ESHPA- Education, Sport, Health and Physical Activity*, 1(1), 41-58. <http://hdl.handle.net/10481/48961>
- Han, Q., Zheng, B., Agostini, M., Belanger, J.J., Gutzkow, B., Kreienkamp, J., Reitseman, A.M., van Breen, J.A. y Leander, N.P. (2021). Associations of risk perception of COVID-19 with emotion and mental health during the pandemic. *Journal of Affective Disorders*, 284, 247-255. <https://doi.org/10.1016/j.jad.2021.01.049>
- Kayani, S., Kiyani, T., Kayani, S., Morris, T., Biastutti, M. y Wang, J. (2021). Physical Activity and Anxiety of Chinese University Students: Mediation of Self-System. *International Journal of Environmental Research and Public Health*, 18(9), 1-13. <https://doi.org/10.3390/ijerph18094468>
- Li, C.X., Ivarsson, A., Lam, L.T. y Sun, J. (2019). Basic Psychological Needs Satisfaction and Frustration, Stress, and Sports Injury Among University Athletes: A Four-Wave Prospective Survey. *Frontiers in Psychology*, 10, 1-8. <https://doi.org/10.3389/fpsyg.2019.00665>
- Linares-Manrique, M., Linares-Girela, D., Schmidt-Rio-Valle, J., Mato-Medina, O., Fernández-García, R., & Cruz-Quintana, F. (2016). Relación entre autoconcepto físico, ansiedad e IMC en estudiantes universitarios mexicanos / The Relation of Physical Self-Concept, Anxiety, and BMI Among Mexican University Students. *Revista Internacional De Medicina Y Ciencias De La Actividad Física Y Del Deporte*, (63). <https://doi.org/10.15366/rimcafd2016.63.007>
- Mabuta, K.D. y Leapetswe, M. (2016). Self-determined and achievement motivation profiles of youth elite athletes: A cultural extension of the achievement goal theory. *Journal of Sport & Exercise Psychology*, 38, 225.
- Marchena, C., Bernabéu, E. e Iglesias, M.T. (2020). Are adherence to the Mediterranean Diet, Emotional Eating, Alcohol Intake, and Anxiety related in University Students in Spain? *Nutrients*, 12(8), 1-15. <https://doi.org/10.3390/nu12082224>
- McDonald, R. P. y Marsh, H. W. (1990). Choosing a multivariate model: noncentrality and goodness of fit. *Psychological Bulletin*, 107, 247-255.
- Melguizo-Ibáñez, E., Zurita-Ortega, F., Ubago-Jiménez, J.L., López-Gutiérrez, C.J., & González-Valero, G: (2022). An explanatory model of the relationships between sport motivation, anxiety and physical and social

- self-concept in educational sciences students. *Current Psychology*, 1-11. <https://doi.org/10.1007/s12144-022-02778-9>
- Muros, J.J., Cofre-Bolados, C., Arriscado, D., Zurita, F. y Knox, E. (2017). Mediterranean diet adherence is associated with lifestyle, physical fitness, and mental wellness among 10-y-olds in Chile. *Nutrition*, 35, 87-92. <https://doi.org/10.1016/j.nut.2016.11.002>
- Newton, M., Duda, J.L. y Yin, Z. (2000). Examination of the psychometric properties of the Perceived Motivational Climate in Sport Questionnaire-2 in a sample of female athletes. *Journal of Sport Sciences*, 18, 275-290.
- Nicholls, J. G. (1989). *The competitive ethos and democratic education*. Harvard University Press.
- Sánchez, M., Sánchez-Sánchez, J., Carcedo, R., & García, J. (2020). Clima, orientación motivacional y diversión en futbolistas alevines. *Revista Internacional De Medicina Y Ciencias De La Actividad Física Y Del Deporte*, 20(79), 507–520. <https://doi.org/10.15366/rimcafd2020.79.008>
- Santos-Labrador, R.M. (2018). Mediterranean Diet in Teenagers: Relation to their gender, place of residence, physical activity level and self-perceived health. *Nutrición Clínica y Dietética Hospitalaria*, 38(2), 86-91. <https://doi.org/10.12873/382santos>
- Sanz, J. y Navarro, M.E. (2003). Propiedades psicométricas de una versión española del Inventario de Ansiedad de Beck (BAI) en estudiantes universitario. *Ansiedad y Estrés*, 9, 59-84.
- Sanz-Martín, D. (2015). Consideraciones de los maestros de Educación Física de Soria sobre la influencia de la práctica de ejercicio físico en el desarrollo de los niños y prácticas escolares para su mejora. *Revista Andaluza de Medicina del Deporte*, 8(1), 20-47. <https://doi.org/10.1016/j.ramde.2014.10.062>
- Schröder, H., Fitó, M., Estruch, R., Martínez-González, M.A., Corella, D., Salas-Salvadó, J., Lamuela-Reventós, R., Ros, E., Salaverría, I., Fiol, M., Lapetra, J., Vinyoles, E., Gómez-Gracia, E., Lahoz, C., Serrá-Majem, L., Pintó, X., Ruiz Gutiérrez, V. y Covas, M.I. (2011). A Short Screener Is Valid for Assessing Mediterranean Diet Adherence among Older Spanish Men and Women. *The Journal of Nutrition*, 141(6), 1140-1145. <https://doi.org/10.3945/jn.110.135566>
- Slack, N.J., Singh, G., Ali, J., Lata, R., Mudaliar, K. y Swamy, Y. (2020). Influence of fast-food restaurant service quality and its dimensions on customer perceived value satisfaction and behavioural intentions. *British Food Journal*, 123(4), 1324-1344. <https://doi.org/10.1108/BFJ-09-2020-0771>
- Stanton, R., To, Q.G., Khalesi, S., Williams, S.L., Alley, S.J., Thwaite, T.L., Fenning, A.S. y Vandelanotte, C. (2020). Depression, Anxiety and Stress during COVID-19: Associations with Changes in Physical Activity, Sleep, Tobacco and Alcohol Use in Australian Adults. *International Journal of Environmental Research and Public Health*, 17(11), 1-13. <https://doi.org/10.3390/ijerph17114065>
- Tahtinen, R.E. y Kristjansdottir, H. (2019). The Influence of Anxiety and Depression Symptoms on Help-Seeking Intentions in Individual Sport Athletes and Non-Athletes: The Role of Gender and Athlete Status. *Journal of Clinical Sport Psychology*, 13(1), 134-151. <http://dx.doi.org/10.1123/jcsp.2017-0028>

- Teichert, T., Rezaei, S. y Correa, J.C. (2020). Customers' experiences of fast-food delivery services: uncovering the semantic core benefits, actual and augmented product by text mining. *British Food Journal*, 122(11), 3513-3528. <https://doi.org/10.1108/BFJ-12-2019-0909>
- Tenenbaum, G. y Eklund, R. C. (2007). *Handbook of sport psychology*. John Wiley & Sons.
- Trigueros, R., Aguilar-Parra, J. M., Álvarez, J. F., Cangas, A. J., & López-Liria, R. (2020). El efecto de la motivación sobre la resiliencia y la ansiedad del deportista. *Revista Internacional De Medicina Y Ciencias De La Actividad Física Y Del Deporte*, 20(77), 73–86. <https://doi.org/10.15366/rimcafd2020.77.005>
- Trigueros, R., Padilla, A.M., Aguilar-Parra, J.M., Rocamora, P., Morales-Gazquez, M.J. y López-Liria, R. (2020). The Influence of Emotional Intelligence on Resilience, Test Anxiety, Academic Stress and the Mediterranean Diet. A Study with University Students. *International Journal of Environmental Research and Public Health*, 17(6), 1-12. <http://dx.doi.org/10.3390/ijerph17062071>
- Ubago-Jiménez, J.L., Zurita-Ortega, F., San Román-Mara, S., Puertas-Molero, P. y González-Valero, G. (2020). Impact of Physical Activity Practice and Adherence to the Mediterranean Diet in Relation to Multiple Intelligences among University Students. *Nutrients*, 12(9), 1-12. <https://doi.org/10.3390/nu12092630>
- Wang, C.K.J., Tan, L. y Dairianathan, E.I. (2018). Achievement Goals, Implicit Theories, and Intrinsic Motivation: A Test of Domain Specificity Across Music, Visual Art, and Sports. *Journal of Research in Music Education*, 66(3), 320-337. <https://doi.org/10.1177/0022429418784563>
- Zurita-Ortega, F., Muros-Molina, J.J., Rodríguez-Fernández, S., Zafra-Santos, E.O., Knox, E. y Castro-Sánchez, M. (2016). Associations of motivation, self-concept and resilience with the competitive level of Chilean judokas. *Archives of Budo*, 12, 201-209.

Número de citas totales / Total references: 44 (100%).

Número de citas propias de la revista / Journal's own references: 4 (9,09%).