

Castro-Sánchez, M.; Zurita-Ortega, F.; Zafra-Santos, E.; Rodríguez-Fernández, S.; Chacón-Cuberos, R. y Valdivia-Moral, P. (2019) Motivación en la práctica del judo en deportistas no profesionales / Motivation of Judo Practice in Non-Professional Athlete. Revista Internacional de Medicina y Ciencias de la Actividad Física y el Deporte vol. 19 (74) pp. 243-258
[Http://cdeporte.rediris.es/revista/revista74/artmotivacion1030.htm](http://cdeporte.rediris.es/revista/revista74/artmotivacion1030.htm)
DOI: <http://doi.org/10.15366/rimcafd2019.74.005>

ORIGINAL

MOTIVATION IN THE PRACTICE OF JUDO IN NON-PROFESSIONAL ATHLETES

MOTIVACIÓN EN LA PRÁCTICA DEL JUDO EN DEPORTISTAS NO PROFESIONALES

Castro-Sánchez, M.¹; Zurita-Ortega, F.¹; Zafra-Santos, E.²; Rodríguez-Fernández, S.¹; Chacón-Cuberos, R.¹; Valdivia-Moral, P.¹

¹ Dr. Educación Física. Universidad de Granada (Spain) manuelcs@ugr.es, felixzo@ugr.es, soniarf@ugr.es, rchacon@ugr.es, pvaldivia@ugr.es

²Dr. Educación Física. Universidad Santo Tomás (Chile) edsonzaf@gmail.com

Spanish-English translator: Laura Arranz Bannon, lauban3@hotmail.com

Código UNESCO / UNESCO code : 6114.03 Psicología social.

Comportamiento Colectivo / Social psychology. Collective Behaviour

Clasificación del Consejo de Europa / Classification Council of Europe:

15. Psicología del deporte / Sport Psychology

Recibido 25 de julio de 2017 **Received** July 25, 2017

Aceptado 6 de febrero de 2018 **Accepted** February 6, 2018

ABSTRACT

The aim of this study is to determine and analyse the relationships and differences in the motivational climate, based on the competitive level in non-professional judokas. A sample of 121 non-professional Chilean judokas (70 men and 51 women) aged between 18 and 40, coming from seven different judo clubs took part. They completed a self-registration sheet of sociodemographic variables and a motivational climate questionnaire (PMCSQ-2). The results indicate that the task goal orientation prevails in non-professional judokas and as the level rises, in amateur athletes the ego goal orientation takes on greater importance. The main deduction is that amateur judokas distinguish in a greater proportion between personal improvement and effort (task goal orientation) and show a greater physical ability than others. This is opposed to what happens with non-professionals, where the correlation between both is lower, although still negative.

KEYWORDS: motivational climate; judo; non-professional; amateur.

RESUMEN

El presente estudio tiene como objetivo determinar y analizar las relaciones y diferencias existentes entre el clima motivacional, en base al nivel competitivo en judocas no profesionales. Participaron un total de 121 judocas chilenos no profesionales (70 hombres y 51 mujeres) con edades comprendidas entre los 18 y 40 años, provenientes de siete clubes de judo. Completaron una hoja de autoregistro de variables sociodemográficas y un cuestionario de clima motivacional (PMCSQ-2). Los resultados indican que en los judocas aficionados predomina el clima tarea y a medida que se asciende en el nivel, en deportistas amateurs cobra una mayor importancia el clima ego. Como principal conclusión destaca que los judocas amateurs distinguen en mayor proporción la diferencia entre la superación personal y el esfuerzo (clima tarea) y demuestran mayor habilidad física que los demás. Al contrario que sucede en los aficionados, donde la correlación entre ambos es inferior, aunque sigue siendo negativa.

PALABRAS CLAVE: clima motivacional; judo; aficionado; amateur.

INTRODUCTION

In the last two decades martial arts have experienced a worldwide expansion, in particular judo in Chile is gaining special relevance in the sport context, where new areas and infrastructures are being created in order to practise this sport, accordingly increasing its practice (Zafra, 2015).

Psychology and sport studies have become priority fields of study and investigation currently; concepts such as anxiety, stress, motivation, resistance or leadership amongst others, are object of study by specialised scientifics in this field (Álvarez, Murillo, Giménez & Manonelles, 2016; Fabra, Balaguer, Castillo, Mercé & Duda, 2013; García-Martín Antúnez & Ibáñez, 2016).

The increasing interest in the understanding of psychological aspects related to sport influences the fact that a person who develops and works with these factors will achieve a higher sport performance (Vaca, Egas, García, Feriz & Freddy, 2017). Therefore, in the martial arts context, Piepiora, Witkowski and Migasiewicz (2017) point out the importance of the high-performance athlete's psychological training, indicating that the training of cognitive capacities and abilities should improve the athlete's self-control, development of the anticipation ability, motivation, emotional control and improvement of confidence, amongst other fundamental aspects (Riera, Caracuel, Palmi & Daza, 2017; Valdivia, 2016).

Motivation in sports is a key factor which will determine efficiency in different sport categories (Chang, Najarian, Chang, Hill & Lee, 2017). The research about motivation in this study focuses on motivational climate, which represents the group of indicators perceived by people in their environment, whether sporting,

educational, etc., by means of which failure or success will be defined (Ames, 1992). The Achievement Goal Theory presents a solid motivational setting by means of which diverse behaviours in the practice of sports can be explained (Nichols, 1989). This theory is considered to be one of the highest impact conceptual approximations concerning motivation in sporting contexts (Duda, 2001). A plurality of researchers who have adopted this psychological approach bring to light the idea of the eagerness of the athlete to show his abilities, considering this factor as the main behavioural activator, whether in training situations (Fabra et al., 2013), competition situations (Korobeynikov, Korobeynikova, Romanyuk, Dakal & Danko, 2017), or other situations where intrinsic motivation prevails such as cooperation, amusement, satisfaction, interest or personal improvement (Ntoumanis et al., 2017), and that means a greater interest in fun and satisfaction regarding the practice of physical activity (Kumar, Singh, Sandhu, Gupta & Pandey, 2017).

In the sporting context, coaches will be the ones to promote environments oriented towards task (mastery) or towards ego (performance) based on the success guideline used (Castuera, Navarrete, Román, & Rabaz, 2015). If the coach focuses on the result, it will be promoting a motivational climate oriented towards ego (comparison between teammates and outperformance of others), whereas if it focuses on the process (self-improvement and effort) it will be promoting a goal oriented towards task (Almagro, 2012). The ego-oriented goal is directly related to high levels of anxiety in athletes, due to the strain inflicted by the need for demonstrating their abilities and outperforming their teammates, resulting in personal development problems (Eliff & Huertas, 2015). Therefore, athletes will be oriented either towards task or towards ego, depending a great deal on the motivational climate promoted by the coach (Morgan, 2017)

There is an increasing interest in the investigation clarifying different aspects related to the martial arts practice and competition, concerning physical and anthropometric features of fighters, tactical and technical issues and psychological aspects (Podrigalo et al., 2017). Judo does not trail behind, since being an Olympic sport it gains vital importance, therefore becoming the investigation of technical aspects necessary in this sport, such as tactical, anthropometric and psychological aspects (Mateo-Cubo & Montero-Carretero, 2017). Researches carried out in this sport present technical-tactical aspects (Dopico, Iglesias-Soler, Carballeira, Mayo, Ardá, & González-Freire, 2014; Drigo, Souza, Cesana & Gomes, 2011), biomechanical or physiological analysis (Escobar-Molina, Rodríguez-Ruiz, Gutiérrez-García & Franchini, 2015; Mala, Maly, Zahalka, Heller, Hrasky & Vodicka, 2015), psychological aspects (Kavoura, Ryba, & Chroni, 2015; Vertonghen, Theeboom, & Pieter, 2014; Ziv & Lidor, 2013) or issues related to injuries resulting from its practice (Kawczynski et al., 2015; Keun-Suh, Ki-Jun, Jaekoo, & Byung, 2015) observing the interrelation between physical, technical-tactical and psychological factors and their influence on performance.

The martial arts field of research is still a fertile field which offers countless possibilities, due to the fact that most of the researches focus on high-performance sport, leaving aside ludic practice; an example of these are the researches carried out in Spain relating to judo, by Reche, Tutte and Ortín

(2014) or the ones by Scislak, Rokita and Blach (2015) in Poland, Malta et al. (2015) in the Czech Republic or Keun-Suh et al. (2015) in South Korea, investigating motivational, morphological and injury incidence factors.

Although studies carried out since the beginning of the century in different contexts have been substantial, they have rarely dealt with motivational climate in judo focusing on non-professional levels; Vertonghen et al.'s studies (2014), establish the psychosocial features in martial arts athletes; Omiya et al.'s study (2014) or Pocecco and Burtcher's (2013), establish differences according to gender in multiple sport specialities including judo, but never analyzing motivation in non-professional competitive levels.

The importance of psychology in judo is expressed in the research carried out by Crivelli, Carrera and Fernández-Dols (2015), who point out that psychological condition affects the judoka's performance directly in such a way that the opponent can sense the emotional state, consequently adapting his strategies and acts to his own psychological state and his rival's. If we focus on differences between sexes, Anshel and Payne's study (2006) reveals that women are less self-confident than men, who show higher levels of anxiety facing stimuli produced by competitive situations.

This research analyses non-professional judokas, who do not compete, simply train, and amateur judokas, who take part in non-professional competitions (amateur).

For these reasons, it is suggested as a hypothesis that in judo there is a clear orientation towards task, besides assuming that in non-professional judokas the main motivational goal will be task versus ego, whereas rising to competitive level, in amateur judokas ego goal will gain importance. The aim of this research is to determine and analyse the relationships and differences between the motivational climate in judo based on the competitive level in amateur and non-professional levels.

METHOD

Participants

A sample of 121 Chilean non-professional judokas participated in this descriptive research (they do not compete in semi-professional nor professional categories); an incidental sampling was carried out considering the category (amateur or non-professional) and the sex (men or women), in order to have a representative sample. Aged between 18 and 40 ($M=23.09$; $SD=6.73$), judokas from 7 different clubs in Chile took part, being 58.1% ($n=70$) of the participants men and 41.9% ($n=51$) women. The amateur group was formed of 60 judokas (36 men and 24 women) with an average age of 21.87 ($SD=5.25$) and the non-professional group was formed by 61 (34 men and 27 women) with an average age of 24.54 ($SD=7.78$). The people analysed trained approximately four times a week for one hour and a half, both non-professionals and amateurs.

Variables and Instruments

This research used the following variables and measurement instruments as a reference:

- a) **Sex**, distinguishing between Male or Female, gathering the information through an ad-hoc questionnaire.
- b) **Age**, registered by a questionnaire created by ourselves (ad-hoc).
- c) **Competitive level**, registered by an ad-hoc questionnaire, establishing the categories Amateur (if the athlete is affiliated and competes in the amateur category) and Non-professional (if the athlete does not compete).
- d) **Motivational goal (PMCSQ-2)**, drawn from the original version "Cuestionario de Clima Motivacional Percibido en el Deporte" by Newton, Duda and Yin (2000) and adapted to Spanish by González-Cutre, Sicilia and Moreno-Murcia (2008), where by means of a Likert scale with five options ranging from 1= totally in disagreement to 5= totally in agreement, 33 items are evaluated. Additionally this test establishes two different categories, Task Goal Orientation (Cooperative Learning, Effort/Improvement and Vital Role) and Ego Goal Orientation (Punishment for Mistakes, Unequal Recognition and Rivalry between Members of the Group). The internal consistency (Cronbach's alpha) of the instrument obtained by González-Cutre et al. (2008) in its adaptation to Spanish had a $\alpha = 0.90$ in Ego Goal ($\alpha = 0.77$ for punishment for mistakes, $\alpha = 0.87$ for unequal recognition and $\alpha = 0.61$ for rivalry) and a $\alpha = 0.84$ in Task Goal ($\alpha = 0.65$ for cooperative learning, $\alpha = 0.70$ for effort/improvement and $\alpha = 0.70$ for vital role). In this research we obtained a $\alpha = 0.79$ for the questionnaire in general, whereas a $\alpha = 0.86$ was obtained for the Task Goal and a $\alpha = 0.89$ for the Ego Goal; for each of the different measurements the Cronbach's alpha were $\alpha = 0.79$ in cooperative learning, $\alpha = 0.75$ in effort/improvement, $\alpha = 0.75$ in vital role, $\alpha = 0.68$ in punishment for mistakes, $\alpha = 0.89$ in unequal recognition, and $\alpha = 0.63$ in rivalry between members of the groups.

Procedure

Permission was granted by the Ethics Committee for the Investigation of the University in Santo Tomás in Chile (CE UST N° 80/2014), always having the informed consent of the participants and always in strict confidence. The athletes completed the questionnaire anonymously taking them approximately fifteen minutes. Two of the researchers of the study were present during the collection of the data in order to solve any doubt in that regard; it must be noted that after the collection of data, 28 questionnaires out of 149 registered were removed because they were incomplete.

Data Analysis

In order to analyse the relations between the variables under consideration, a model of structural connections was made regarding the effects between the different constructs involved in the study using the programme AMOS 21 and the programme SPSS 22 in order to determine the basic statistical descriptions.

RESULTS

Aiming to accomplish one of the goals brought up by the analysis of the relations between the variables in the study, a model of structural connections was made in order to estimate the effects or relations between different constructs involved, using programme AMOS 21.

A model has been estimated regarding multigroup or multisample structural equations aiming to contrast the existence of relations between the task goal and the ego goal orientations and between these and their indicators.

The model is made up of six observable variables or indicators and two latent variables or constructs that supposedly measure the indicators (Bollen, 1989). In this model, causal explanations are given related to the latent variables based on observed relations between the indicators, keeping in mind the reliability of the measurements, since they include the measuring mistakes in the model, allowing a direct control.

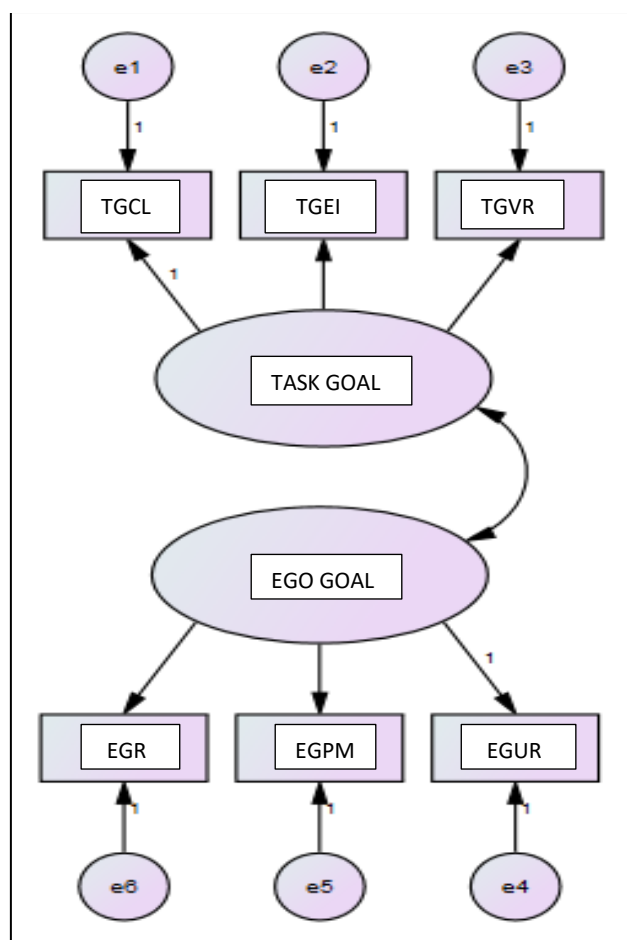

Figure 1 Theoretical Model: Task goal orientation - Ego goal orientation

Note. TGCL, Task-goal cooperative learning; TGEI, Task-goal effort/improvement; TGVR, Task-goal vital role; EGR, Ego-goal rivalry; EGPM, Ego-goal punishment for mistakes; and EGUR, Ego-goal unequal recognition.

The variables task-goal and ego-goal act as exogenous latent variables and are inferred by three indicators each: cooperative learning (TGCL); effort/improvement (TGEI); vital role (TGVR); and rivalry (EGR); punishment for mistakes (EGPM); unequal recognition (EGUR), respectively. In order to estimate the parameters the method of maximum authenticity (ML) was used, because it was considered to be coherent, not biased and non alterable by the scale and usually distributed, since the observable variables respond to normality conditions.

We try to observe the direct unidirectional effects or mediated relationships between these factors, as well as the bidirectional effects between the latent variables Motivational Climates (task-ego) through a multigroup analysis on the moderating effect in the independent variable sporting level. In this sense, the analysis was carried out in order to check if the relations between the model variables differed depending on the level: amateur or non-professional.

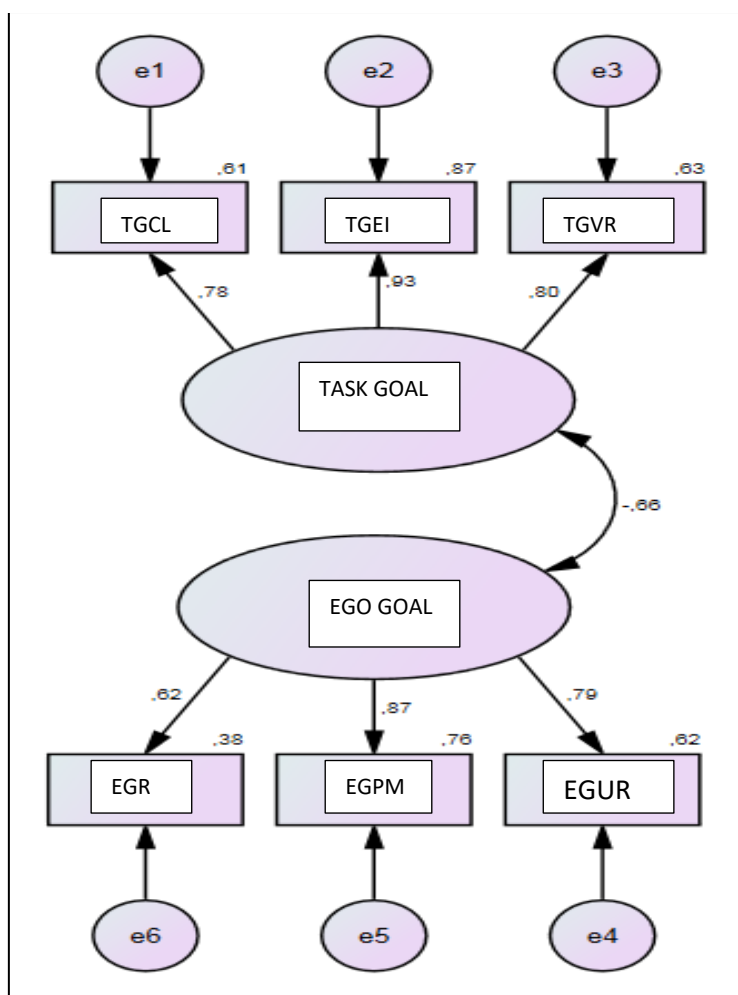

Figure 2. Multigroup structural equations model: amateur

Note. TGCL, Task-goal cooperative learning; TGEI, Task-goal effort/improvement; TGVR, Task-goal vital role; EGR, Ego-goal rivalry; EGPM, Ego-goal punishment for mistakes; and EGUR, Ego-goal unequal recognition.

In figure 2 we can observe the standardised saturation weights between the latent variables or factors and their indicators taking into account the masculine gender, in the gender variable. It is considered that the indicator should have at least 50% of its variance in common with the latent variable. The relations established between the latent variables and observed variables or indicators show percentages over 0.50 in their variance.

Table 1. Regressive weights and multigroup standardised regressive weights: amateur

Relation between variables			R.W.				SRW
			Estimates	E.E	C.R.	p	Estimates
TGCL	<--	TASK GOAL	1,000				0,778
TGEI	<--	TASK GOAL	0,932	0,144	6,452	***	0,935
TGVR	<--	TASK GOAL	1,044	0,182	5,753	***	0,797
EGUR	<--	EGO GOAL	1,000				0,787
EGPM	<--	EGO GOAL	0,838	0,158	5,309	***	0,874
EGR	<--	EGO GOAL	0,648	0,160	4,060	***	0,617
TASK GOAL	<-->	EGO GOAL	-0,249	0,085	-2,918	***	-0,662

Note: R.W.: Regressive weights; S.R.W.: Standardised regressive weights; E.E.: Error estimation; C.R.: Critical Ratio.

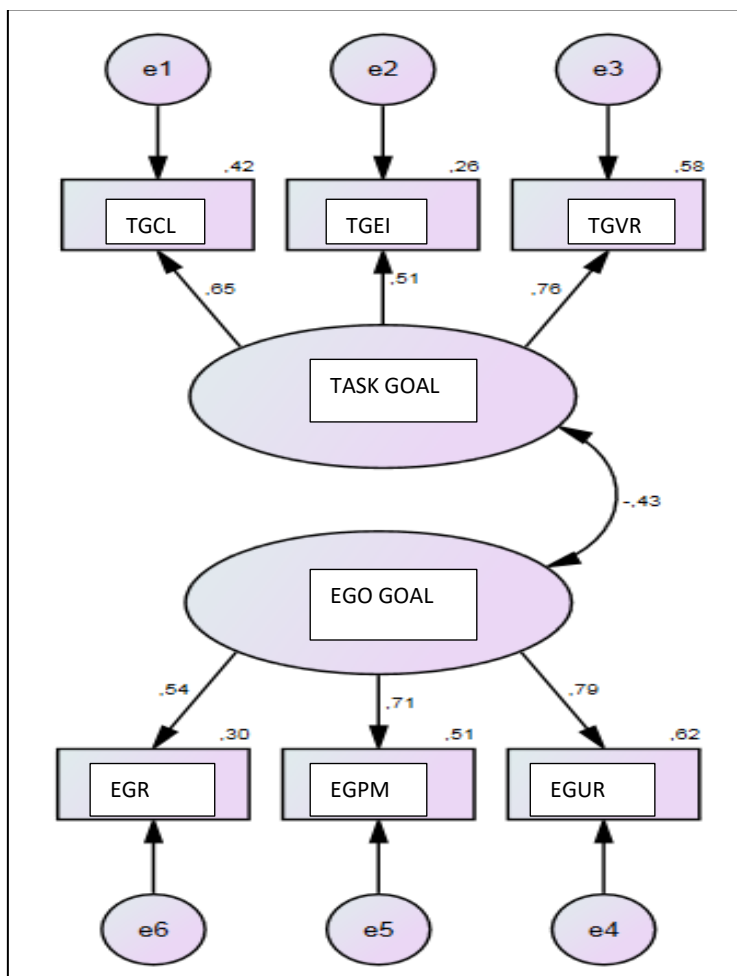

Figure 3. Multigroup structural equations model: non-professionals

Note. TGCL, Task-goal cooperative learning; TGEI, Task-goal effort/improvement; TGVR, Task-goal vital role; EGR, Ego-goal rivalry; EGPM, Ego-goal punishment for mistakes; and EGUR, Ego-goal unequal recognition.

In figure 3 we can see the standardisation of the data corresponding to non-professional level. We can note, in the first place, the existing correlation between the variables Task goal and Ego goal, being as much in amateurs as in non-professionals, negative and significant. There is a stronger association between both variables in amateur level. In the physical education and sport setting, amateurs establish a stronger negative correlation between both motivational climates. Amateurs distinguish to a greater extent between personal development and effort (task goal) and outperforming others, as opposed to non-professionals, where correlation between them is lower, although still negative. For the latter, the difference between both motivational climates is not so important.

Regarding relations between latent variables and observed or indicators in the non-professional level, they show percentages over 0.50 in their variance.

Table 2. Regressive weights and multigroup standardised regressive weights: non-professionals

Relation between variables			R.W.				S.R.W
			Estimates	E.E.	C.R.	p	Estimates
TGCL	<--	TASK GOAL	1,000				0,648
TGEI	<--	TASK GOAL	0,711	0,288	2,468	***	0,511
TGVR	<--	TASK GOAL	1,197	0,457	2,619	***	0,760
EGUR	<--	EGO GOAL	1,000				0,790
EGPM	<--	EGO GOAL	0,876	0,280	3,132	***	0,713
EGR	<--	EGO GOAL	0,770	0,274	2,813	***	0,544
TASK GOAL	<-->	EGO GOAL	-0,779	0,246	-3,166	***	-0,432

Note: R.W.: Regressive weights; S.R.W.: Standardised regressive weights; E.E.: Error estimation; C.R.: Critical Ratio

Lastly, and in order to check the compatibility of the proposed model and the gathered empirical information, we evaluate the adjustment of the model. Thus, Chi-square shows a non significant associated value of p ($\chi^2=75.995$; $df.=16$; $p=0.001$) although we have to bear in mind that this statistic has no index superior limit and thus it is not possible to interpret it in a standardised way, in addition to the problem of its sensitivity to the sample size. Therefore, other standardised setting indexes, less sensitive to the sample size, are used (Jöreskog, 1977).

The Goodness-of-Fit Index (GFI) obtains a value of 0.912, which indicates a suitable adjustment to the model, the same as the Comparative Fit Index (CFI) which has a value of 0.907 (Hu and Bentler, 1998). The value of the Incremental Fit Index (IFI) also has suitable values (0.856) (Bollen, 1989). Finally, the value of RMSEA is below 0.1, which shows an acceptable adjustment (0.080) to the established parameters (Browne and Cudeck, 1993). In short, there is a good adjustment of the model to the empirical data.

DISCUSSION

This research completed on 121 non-professional and amateur judokas from Chile is similar to others carried out in different martial arts and combat sports contexts by Calmet and Ahmaidi (2004); Escobar-Molina et al. (2015); Filaire, Larue & Rouveix (2010); Keun-Suh et al. (2015) or Mala et al. (2015), amongst others, it has been carried out using structural equations, standing out, in the first place, the precise adjustment of the model to the empirical data, as aforementioned.

Judo has a very particular philosophy, according to which coaches are highly concerned about the athletes' welfare, good relationships between the members of the team and the provision of a harmonious atmosphere in the working groups, in such a way that, in spite of being an individual sport, the aim is to increase the competitive level showing signs of generosity towards the teammates during the practice (Sava & Panaitescu, 2017; Zafra, 2015).

The considered hypothesis is confirmed, showing in the judokas a predominant orientation towards task, and an increase in the ego goal orientation in amateur athletes is also confirmed, due to the results achieved in this research, where

the typology of the athletes is rather predictable in respect of motivational climate, prevailing for non-professional judokas task goal orientation and as the level rises in amateur athletes ego goal orientation gains importance. This behaviour is in line with reports by Holgado, Navas, López-Nunes, and García Calvo (2010) and Ruiz, Haapanen, Tolvanen, Robazza and Duda (2017), who point out that the motivational climate is mainly related to the athlete's level, valuing in lower levels cooperation or rewarding effort (task goal), while professionals reward the result or offer recognition only to those whose physical performance stands out (ego goal).

The obvious predominance of task goal orientation in this sample highlights a clear interest of the person in developing a liking for judo, the search for pleasure through the practice of sport and the development of technical-tactical aspects which will enable them to improve their competitive level, being able to consider this group as a group of athletes with a high intrinsic motivational level (Moreno-Murcia, Borges-Silva, Marcos-Pardo, Sierra-Rodríguez & Huéscar-Hernández, 2012). This allows the appropriate development of individual abilities and sport specialisation (Vink, Raudsepp & Kais, 2015). One of the results of the establishment of the task goal orientation is achieving a higher recognition of the athletes' own abilities in order to overcome challenges, this being defined as *flow* (Çağlar, Aşçi & Uygurtaş, 2017).

Regarding judo, Ruiz (2007) carried out an analysis relative to leadership features in a group of judo coaches in Spain, confirming their tendency to promote the development of the motivational climate oriented towards task based on social interaction and team spirit, all the more since it is a sporting discipline where the relationship with the coaches is considered a teacher-pupil one, which strengthens the union and the compromise by the athletes. The discoveries described in this study coincide with those suggested in scientific literature.

As the specialisation degree and mastery in a sport improves, the main motivation towards it is progressively modified. In the early stages, when the practice of a sport focuses on encouraging physical activity, grounds and team values, the task goal orientation performs the main motivational role. Over the years of practice the athlete's sense of identity grows, reinforced by his environment recognition, the technical-tactical aspect of its sport is considered an efficient means of achieving or maintaining success, and in this respect the motivational climate oriented towards ego is progressively made more obvious (Lochbaum, Kallinen & Kontinen, 2017).

We understand that if we handled a sample made solely of high-performance athletes, a tendency towards ego goal would be expected, where success is measured according to the degree of recognition in their speciality depending on the number of successful championships, medals won, mainly in international competitions, which is significantly related to the degree of satisfaction with the sporting activity (Zarauz & Ruiz, 2013).

It is interesting to point out that the limited number of judokas stands out as one of the main limitations of this research. It would be interesting to increase their number and the number of martial arts sports under study, including sports such as karate or taekwondo. What is more, it would be interesting to carry out subsequent studies containing athletes in professional competitive levels and team sports which would allow a comparison between sports and levels, bearing in mind physical, technical, tactical and psychological aspects (Zurita, 2015).

As a conclusion to this research we point out that the negative interrelationship between task goal and ego goal based on the competitive level, is stronger in amateur judokas, distinguishing to a greater extent between self-improvement and effort, as opposed to non-professionals, where the interrelationship between them is lower, showing a lesser difference between both motivational climates.

Practical effects are quite wide, providing data to judo coaches which will allow them to apply motivational climate with the assistance of the sports psychologist, introducing actions that will bring greater motivation to their athletes.

REFERENCES

- Almagro, B. J. (2012). *Factores motivacionales relacionados con la adherencia a la práctica deportiva competitiva en adolescentes*. Tesis doctoral: Universidad de Huelva.
- Álvarez, J., Murillo, V., Giménez, L., & Manonelles, P. (2016). Modificación del volumen-intensidad como medida preventiva de lesiones en fútbol sala. *Revista Internacional de Medicina y Ciencias de la Actividad Física y del Deporte*, 16(61), 85-97. DOI: 10.15366/rimcafd2016.61.007
- Ames, C. (1992). Achievement goals, motivational climate, and motivational processes. En Roberts, G. (Ed.), *Motivation in sport and exercise* (pp. 161-176). Champaign, IL: Human Kinetics.
- Anshel, M., & Payne, J. (2006). Application of Sport Psychology for Optimal Performance in Martial Arts, en J. Dosil (ed.), *The Sport Psychologist's Handbook* (pp. 353-374). UK: John Wiley & Sons.
- Bollen, K.A. (1989). *Structural Equations with Latent Variables*. New York: John Wiley & Sons, Inc.
- Browne, M. W., & Cudeck, R. (1993). Alternative ways of assessing model fit. En: K. A. Bollen & J. S. Long (Eds.), *Testing structural equation models* (pp. 136-162). Beverly Hills, CA: Sage.
- Çağlar, E., Aşçi, F. H., & Uygurtaş, M. (2017). Roles of perceived motivational climates created by coach, peer, and parent on dispositional flow in young athletes. *Perceptual and motor skills*, 124(2), 462-476. DOI: 10.1177/0031512516689404
- Calmet, M., & Ahmaidi, S. (2004). Survey of advantages obtained by judoka in competition by level of practice. *Perceptual and Motor Skills*, 99(1), 284-290. DOI: 10.2466/pms.99.1.284-290

- Castuera, R., Navarrete, B., Román, M., & Rabaz, F. (2015). Motivación y estadios de cambio para el ejercicio físico en adolescentes. *Revista Latinoamericana de Psicología*, 47(3), 196-204. DOI: 10.1016/j.rlp.2014.11.001.
- Chang, E. C., Najarian, A. S., Chang, O. D., Hill, G. B., & Lee, J. (2017). Athletic Competence as a Central Facet of Sport Orientation Among Collegiate Athletes. *Journal of Sport Behavior*, 40(3), 269-277.
- Crivelli, C., Carreera, P., & Fernández-Dols, J. M. (2015). Are smiles a sign of happiness? Spontaneous expressions of judo winners. *Evolution and Human Behavior*, 36, 52-58. DOI: 10.1016/j.evolhumbehav.2014.08.009
- Dopico, X., Iglesias-Soler, E., Carballeira, E., Mayo, X., Ardá, A., & González-Freire, M. (2014). The relationship between motoric dominance and functional dominance while executing judo techniques: a study on laterality. *Archives of Budo*, 10, 325-331.
- Drigo, A., Neto, S., Cesana, J., & Tojal, J. (2011). Artes marciais, formação profissional e escolas de ofício: Análise documental do judô brasileiro. *Motricidade*, 7(4), 49-62. DOI: 10.6063/motricidade.7(4).88
- Duda, J. L. (2001). Achievement goal research in sport: pushing the boundaries and clarifying some misunderstandings. En G. C. Roberts (Ed.), *Advances in motivation in sport and exercise* (pp.129-182). Champaign, IL: Human Kinetics.
- Elliff, H. & Huertas, J. (2015). Clima motivacional de clase: en búsqueda de matices. *Revista de Psicología*, 11(21), 61-74.
- Escobar-Molina, R., Rodríguez-Ruiz, S., Gutiérrez-García, C., & Franchini, E. (2015). Weight loss and psychological-related states in high level judo athletes. *International Journal of Sport Nutrition and Exercise Metabolism*, 25(2), 110-118. DOI: 10.1123/ijsnem.2013-0163
- Fabra, P., Balaguer, I., Castillo, I., Mercé, J., & Duda, J. L. (2013). La eficacia de rol como mediadora entre el clima motivacional y el rendimiento en jóvenes futbolistas. *Revista de Psicología Social*, 28(1), 47-58. DOI: 10.1174/021347413804756023
- Filaire, E., Larue, J., & Rouveix, M. (2010). Eating Behaviours in Relation to Emotional Intelligence. *International Journal of Sports Medicine*, 32(4), 309-315. DOI: 10.1055/s-0030-1269913
- García-Martín, A.; Antúnez, A., & Ibáñez, S. J. (2016). Análisis del proceso formativo en jugadores expertos: validación de instrumento. *Revista Internacional de Medicina y Ciencias de la Actividad Física y el Deporte*, 16(61), 157-182. DOI: 10.15366/rimcafd2016.61.012
- González-Cutre, D., Sicilia, A., & Moreno-Mucia, J. A. (2008). Modelo cognitivo-social de la motivación de logro en educación física. *Psicothema*, 20(4), 642-651. DOI: 10.5232/ricyde2012.02902
- Holgado, F.P., Navas, L., López-Nunes, M., & García-Calvo, T. (2010). A structural model of goal orientation in sports: personal and contextual variables. *Spanish Journal of Psychology*, 13(1), 257-266. DOI: 10.1017/S1138741600003838
- Hu, L.T., & Bentler, P.M. (1998). Fit indices in covariance structure model-ing: sensitivity to underparameterized model misspecification. *Psychological Methods*, 3, 424-453. DOI: 10.1037/1082-989X.3.4.424
- Jöreskog, K. G. (1977). *Structural Equation Models in the Social Sciences*:

- Specification estimation and testing. En P.R. Krishnaiah (Ed.), *Applications of Statistics*, pp. 265-287. Amsterdam: North Holland.
- Kavoura, A., Ryba, T. V., & Chroni, S. (2015). Negotiating female judoka identities in Greece: A Foucauldian discourse analysis. *Psychology of Sport and Exercise*, 17, 88-98. DOI: 10.1016/j.psychsport.2014.09.011
- Kawczynski, A., Samani, A., Mroczek, D., Chmura, P., Blanch, W., Migasiewicz, J., Chmura, J., & Madeleine, P. (2015). Functional connectivity between core and shoulder muscles increases during isometric endurance contractions in judo competitors. *European Journal of Applied Physiology*, 115(6), 1351-1358. DOI: 10.1007/s00421-015-3114-z
- Keun-Suh, K., Ki-Jun, P., Jaekoo, L., & Byung, K. (2015). Injuries in national Olympic level judo athletes: an epidemiological study. *British Journal of Sports Medicine*, 49(17), 1144-1150. DOI: 10.1136/bjsports-2014-094365
- Korobeynikov, G. V., Korobeynikova, L. G., Romanyuk, L. V., Dakal, N. A., & Danko, G. V. (2017). Relationship of psychophysiological characteristics with different levels of motivation in judo athletes of high qualification. *Pedagogics, psychology, medical-biological problems of physical training and sports*, 21(6), 272-278. DOI: 10.15561/18189172.2017.0603
- Kumar, V., Singh, A., Sandhu, J. S., Gupta, N., & Pandey, R. M. (2017). Comparative study of sports motivation among contact and non-contact sports persons. *International Journal of Physical Education, Sports and Health*, 4(4), 128-131. DOI: 10.26524/1212
- Lochbaum, M., Kallinen, V., & Konttinen, N. (2017). Task and Ego Goal Orientations across the Youth Sports Experience. *Studia sportiva*, 11(2), 99-105.
- Mala, L., Maly, T., Zahalka, F., Heller, J., Hrasaky, P., & Vodicka, P. (2015). Differences in the morphological and physiological characteristics of senior and junior elite Czech judo athletes. *Archives of Budo*, 11, 185-193.
- Mateo-Cubo, F., & Montero-Carretero, C. (2017). Report on the First International Symposium Science in Judo (ISSJ). *Revista de Artes Marciales Asiáticas*, 12(2), 106-111. DOI: 10.18002/rama.v12i2.5193.
- Moreno-Murcia, J. A., Borges-Silva, F., Marcos-Pardo, P. J., Sierra-Rodríguez, A. C., & Huéscar-Hernández, E. (2012). Motivación, frecuencia y tipo de actividad en practicantes de ejercicio físico. *Revista Internacional de Medicina y Ciencias de la Actividad Física y el Deporte*, 12(48), 649-662.
- Morgan, K. (2017). Reconceptualizing motivational climate in physical education and sport coaching: An interdisciplinary perspective. *Quest*, 69(1), 95-112. DOI: 10.1080/00336297.2016.1152984
- Newton, M., Duda, J.L., & Yin, Z. (2000). Examination of the psychometric properties of the Perceived Motivational Climate in Sport Questionnaire-2 in a sample of female athletes. *Journal of Sports Sciences*, 18, 275-290.
- Nicholls, J. G. (1989). *The competitive ethos and democratic education*. Cambridge, MA: Harvard University Press.
- Ntoumanis, N., Stenling, A., Thøgersen-Ntoumani, C., Vlachopoulos, S., Lindwall, M., Gucciardi, D. F., & Tsakonitis, C. (2017). Longitudinal Associations Between Exercise Identity and Exercise Motivation: A

- Multilevel Growth Curve Model Approach. *Scandinavian journal of medicine & science in sports*, 28(2), 746-753.
- Omiya, K., Sekizuka, H., Kida, K., Suzuki, K., Akashi, Y. J., Ohba, H., & Musha, H. (2014). Influence of gender and types of sports training on QT variables in young elite athletes. *European Journal of Sport Science*, 14(1), 32-38. DOI: 10.1080/17461391.2011.641032
- Piepora, P., Witkowski, K., & Migasiewicz, J. (2017). Evaluation of the effects of mental visualisation training in sport with regard to karate shotokan fighters specialising in kata. *Journal of Combat Sports & Martial Arts*, 8(1), 49-53. DOI: 10.5604/01.3001.0010.4655
- Pococco, E., & Burtscher, M. (2013). Sex-differences in response to arm and leg ergometry in juvenile judo athletes. *Archives of Budo*, 9(3), 181-187.
- Podrigalo, L., Iermakov, S., Potop, V., Romanenko, V., Boychenko, N., Rovnaya, O., & Tropin, Y. (2017). Special aspects of psychophysiological reactions of different skillfulness athletes, practicing martial arts. *Journal of Physical Education and Sport*, 17(1), 519-526. DOI: 10.7752/jpes.2017.s2078
- Reche, C., Tutte, V., & Ortín, F.J. (2014). Resiliencia, optimismo y burnout en Judokas de competición Uruguayos. *Revista Iberoamericana de Psicología del Ejercicio y el Deporte*, 9(2), 271-286.
- Riera, J., Caracuel, J. C., Palmi, J. & Daza, G. (2017). Psicología y deporte: habilidades del deportista consigo mismo. *Apunts. Educación física y deportes*, 1(127), 82-93. DOI: 10.5672/apunts.2014-0983.es.(2017/1).127.09.
- Ruiz, M. C., Haapanen, S., Tolvanen, A., Robazza, C., & Duda, J. L. (2017). Predicting athletes' functional and dysfunctional emotions: The role of the motivational climate and motivation regulations. *Journal of sports sciences*, 35(16), 1598-1606. DOI: 10.1080/02640414.2016.1225975
- Ruiz, R. (2007). Características de liderazgo en el deporte del judo. *Revista de Psicología del Deporte*, 16(1), 9-24.
- Sava, M. A., & Panaitescu, A. M. (2017). Study on the Importance of Attention and Combativity in Competitions at Judoka athletes for 11-13 Years. *Gymnasium*, 18(1), 1-12. DOI: 10.1007/s40279-016-0645-3
- Ściślak, M., Rokita, A., & Błach, W. (2015). Interests in mobile activity forms of persons practicing judo. *Archives of Budo*, 11, 235-241.
- Vaca, R., Egas, S., García, O., Feriz, L., & Freddy, A. (2017). Ansiedad precompetitiva en karatecas de alto rendimiento, amateur y novatos. *Revista Cubana de Investigaciones Biomédicas*, 36(2), 1-9.
- Valdivia, P. (2016). *Niveles de ansiedad, autoconcepto y resiliencia en deportes individuales*. Tesis doctoral: Universidad de Granada.
- Vertonghen, J., Theeboom, M., & Pieter, W. (2014). Mediating factors in martial arts and combat sports: an analysis of the type of martial art, characteristics, and social background of young participants. *Perceptual and Motor Skills*, 118(1), 41-61. DOI: 10.2466/06.30.PMS.118k14w3
- Vink, K., Raudsepp, L., & Kais, K. (2015). Intrinsic motivation and individual deliberate practice are reciprocally related: Evidence from a longitudinal study of adolescent team sport athletes. *Psychology of Sport and Exercise*, 16, 1-6. DOI: 10.1016/j.psychsport.2014.08.012
- Zafra, E. O. (2015). *Capacidad de resiliencia frente a lesiones deportivas y su*

- relación con el desempeño deportivo en judocas de Chile*. Tesis doctoral: Universidad de Granada.
- Zarauz, A., & Ruiz, F. (2013). Variables predictoras de la ansiedad en atletas veteranos españoles. *Retos. Nuevas tendencias en Educación Física, Deporte y Recreación*, 23, 29-32.
- Ziv, G., & Lidor, R. (2013). Psychological preparation of competitive judokas- a review. *Journal of Sports Science and Medicine*, 12(3), 371-380.
DOI: 10.12800/ccd.v3i7.152
- Zurita, F. (2015). *Influencia de los factores psicológicos sobre las lesiones deportivas en deportes de equipo*. Tesis Doctoral: Universidad de Jaén.

Número de citas totales / Total references: 54 (100%)

Numero de citas propias de la revista / Journal's own references: 3 (5,55%)